

V4(V7)-ABFW-EPN16

Actuated Wafer type butterfly valves

PRODUCT DATA



FEATURES

- Cast Iron (V4) or SUS304 (V7) Wafer Body
- Centric butterfly valve with elastomer liner
- Wide DN-range (DN 50 ... DN600)
- For On/Off or Modulating Control
- Robust actuators in epoxy coated aluminum
- Manual override non-clutch design. Manual operation can be operated without any lever, clutch or brake upon power voltage.
- Irreversible worm gear
- Visual mechanical position indicator for accurate visual reference of valve position
- Anti-condensation heater and 2 aux. limit switches on standard model
- Enclosure IP67

SPECIFICATIONS

Valve

Sizes	DN50 – DN600(Wafer Type)
Nominal pressure	PN16
Tightness	Bubble tight
Temperature range	-10 ~ 120°C Maximum
Body	FCD45 (V4) or SUS304 (V7)
Shaft	Stainless Steel, 970 416S21
Disc	Ductile Iron or SUS304
Liner	EPDM

Actuator

Motor Voltage	230VAC, 50 / 60 Hz
Current, Running time	See table (1)
Travel Angle	90° ± 5°
Input (Modulating)	4~20mA, 1~5V, or 0(2)~10V select by DIP-switch
Enclosure	IP67 Watertight
Ambient Temperature	-5 °C to +60 °C
Indicator	Continuous Position Indicator
Manual Override	Non-clutch design
Worm Gear	Permanently lubricated and self locking
Mechanical Stops	External Adjustable Limit stops
Space heater	15W 230V Anti-condensation
Material	Steel, Aluminum Alloy, Al Bronze
External Coating	Anodized and dry powder epoxy
Stall Protection	Built-in thermal protection Cut off at 125 ± 5 °C Reset at 95 ± 5 °C

GENERAL

The V4 Actuated Wafer Type Butterfly Valves are suitable for heating and cooling applications. They can also be employed for industrial applications, general services and water treatment.

The V4 series is equipped with standard On/Off or modulating (4~20mA, 1~5V, or 0(2)~10V select by DIP-switch) control quarter-turn electric actuator.

Table (1) Control Type and Valve Size Data

The below table is based on differential pressure of 10 bar.

Valve Size	On/Off Model No.	Actuator Type	Modulating Model No.	Actuator Type	Max Torque (Nm)	Op Time sec/90° at 60Hz	Power (Watts)	Manual Override	Kvs (m³/h)
DN50	V4-ABFW-EPN16-050-01	OM-1	V4-ABFW-EPN16-050-02	OM-P1	35	12	10	Lever	100
DN65	V4-ABFW-EPN16-065-01	OM-1	V4-ABFW-EPN16-065-02	OM-P1	35	12	10	Lever	170
DN80	V4-ABFW-EPN16-080-01	OM-2	V4-ABFW-EPN16-080-02	OM-P2	90	15	40	Hand-wheel	281
DN100	V4-ABFW-EPN16-100-01	OM-2	V4-ABFW-EPN16-100-02	OM-P2	90	15	40	Hand-wheel	619
DN125	V4-ABFW-EPN16-125-01	OM-3	V4-ABFW-EPN16-125-02	OM-P3	150	22	40	Hand-wheel	884
DN150	V4-ABFW-EPN16-150-01	OM-3	V4-ABFW-EPN16-150-02	OM-P3	150	22	40	Hand-wheel	1366
DN200	V4-ABFW-EPN16-200-01	OM-4	V4-ABFW-EPN16-200-02	OM-P4	400	16	120	Hand-wheel	2713
DN250	V4-ABFW-EPN16-250-01	OM-4	V4-ABFW-EPN16-250-02	OM-P4	400	16	120	Hand-wheel	4819
DN300	V4-ABFW-EPN16-300-01	OM-5	V4-ABFW-EPN16-300-02	OM-P5	500	22	120	Hand-wheel	7136
DN350	V4-ABFW-EPN16-350-01	OM-6	V4-ABFW-EPN16-350-02	OM-P6	650	28	120	Hand-wheel	10485
DN400	V4-ABFW-EPN16-400-01	OM-7	V4-ABFW-EPN16-400-02	OM-P7	1000	46	180	Hand-wheel	14007
DN450	V4-ABFW-EPN16-450-01	OM-8	V4-ABFW-EPN16-450-02	OM-P8	1500	46	220	Hand-wheel	18560
DN500	V4-ABFW-EPN16-500-01	OM-9	V4-ABFW-EPN16-500-02	OM-P9	2000	58	180	Hand-wheel	23860
DN600	V4-ABFW-EPN16-600-01	OM-9	V4-ABFW-EPN16-600-02	OM-P9	2000	58	180	Hand-wheel	36900

Figure (1) Product Identification System

The labeling system for Honeywell butterfly valves is as follows:

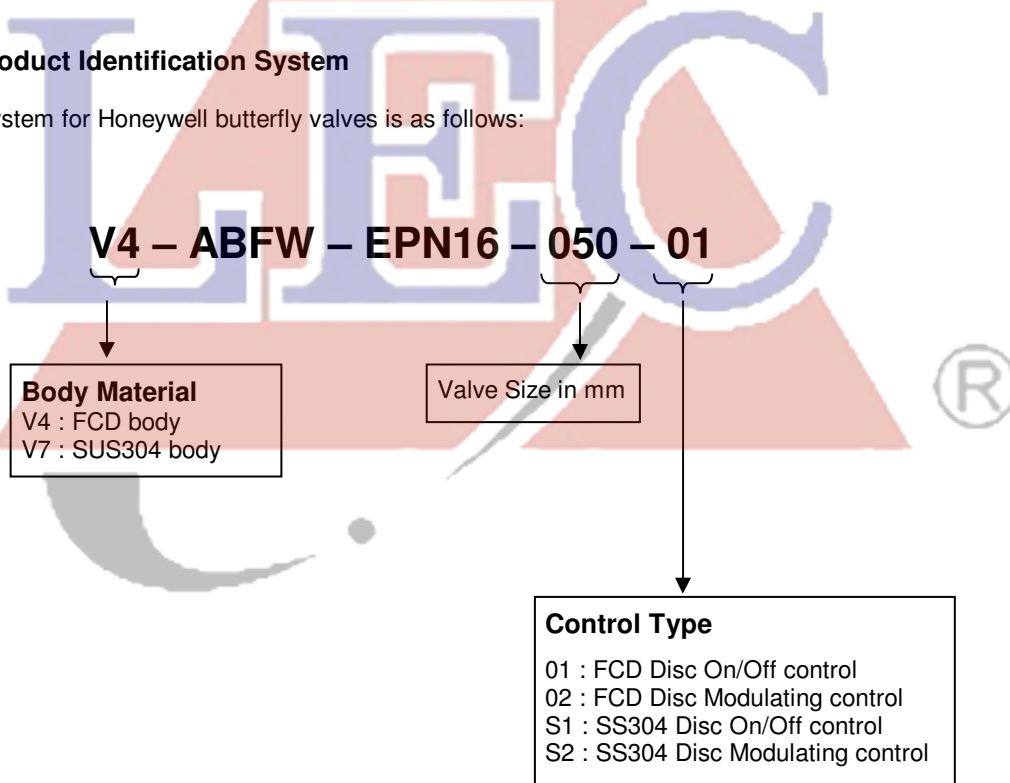

Table (2) Valve Dimensions and Weight

Size	A	B	C1	D	E	F	KxK	Weight (Kg)	Top Plate Date	
									PCD	HOLE N-Dia.
DN50	136	79	103	43	90	30	11x11	4.5	70	4 - Ø9
DN65	146	84	111	46	90	30	11x11	5.4	70	4 - Ø9
DN80	152	94	131	46	90	30	11x11	5.6	70	4 - Ø9
DN100	171	120	157	52.4	90	30	14x14	7.6	70	4 - Ø9
DN125	184	134	186	55.6	90	30	14x14	10.1	70	4 - Ø9
DN150	196	151	207	55.6	90	30	17x17	12.0	70	4 - Ø9
DN200	226	182	268	60	125	45	22x22	16.9	102	4 - Ø11
DN250	258	210	328	68	125	45	27x27	26.4	102	4 - Ø11
DN300	296	245	373	78	125	45	27x27	37.8	102	4 - Ø11
DN350	320	276	421	78	150	45	27x27	67	125	4 - Ø14
DN400	356	320	484	102	175	45	27X27	110	140	4 - Ø18
DN450	380	345	530	114	175	45	36X36	127	140	4 - Ø18
DN500	420	372	579	127	175	45	36X36	160	140	4 - Ø18
DN600	510	442	698	154	210	45	36X36	185	165	4 - Ø22

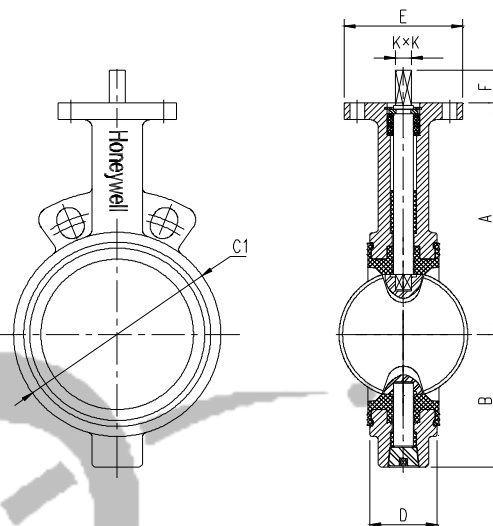

Table (3) Hydraulic Characteristics

The below table shows the Kv – values at different opening angles:

Nominal Size	Kv – value at Disk Opening Angle								
	10°	20°	30°	40°	50°	60°	70°	80°	90°
DN50	0.05	2.60	6.10	13	23	38	61	91	100
DN65	0.09	5.20	10	22	39	65	103	154	170
DN80	0.17	7.80	16	34	61	100	158	238	261
DN100	0.26	15	31	68	120	199	315	472	519
DN125	0.43	25	53	115	205	339	536	804	884
DN150	0.69	39	82	177	317	523	829	1243	1366
DN200	1.70	77	163	353	629	1040	1646	2469	2713
DN250	2.60	131	277	600	1070	1771	2803	4205	4619
DN300	3.50	202	428	927	1653	2735	4329	6494	7136
DN350	5.1	289	611	1324	2360	3904	6179	9268	10185
DN400	6.8	397	840	1821	3245	53639	8497	12746	14007
DN450	9.4	526	1113	2412	4297	7111	11255	16882	18551
DN500	11.9	676	1431	3101	5526	9144	14471	21706	23853
DN600	18.8	1044	2211	4791	8538	14126	22356	33535	36851

Type(ON/OFF)	Type (Modulating)	Type (P1~PH8, 75% , PH9~PH12,50%)	Type(24VAC)	Torque (Nm)	Op Time sec/90° at 60Hz	Power (Watts)	Manual Override
OM-2	OM-P2	OM-PH2	OM-P2F	90	15	40	Hand-wheel
OM-3	OM-P3	OM-PH3	OM-P3F	150	22	40	Hand-wheel
OM-4	OM-P4	OM-PH4	OM-P4F	400	16	120	Hand-wheel
OM-5	OM-P5	OM-PH5	OM-P5F	500	22	120	Hand-wheel
OM-6	OM-P6	OM-PH6	OM-P6F	650	28	120	Hand-wheel
OM-7	OM-P7	OM-PH7	OM-P7F	1000	46	180	Hand-wheel
OM-8	OM-P8	OM-PH8	OM-P8F	1500	46	220	Hand-wheel
OM-9	OM-P9	OM-PH9	OM-P9F	2000	58	180	Hand-wheel
OM-10	OM-10	OM-PH10	OM-P10F	2500	58	220	Hand-wheel
OM-11	OM-11	OM-PH11	OM-P11F	3000	58	250	Hand-wheel

OM-12	OM-12	OM-PH12	OM-P12F	3500	58	300	Hand-wheel
-------	-------	---------	---------	------	----	-----	------------

**Table (4a) Actuator Dimensions
(OM-1)**

Model No.	A	B	C	D	E	F	G	H	I	J	K	L max	M	N	S	Flange Type
OM-1	108	8	45°	155	15	36	m5	4	m6	6	50	14	19	1	½ PT	F03/F05

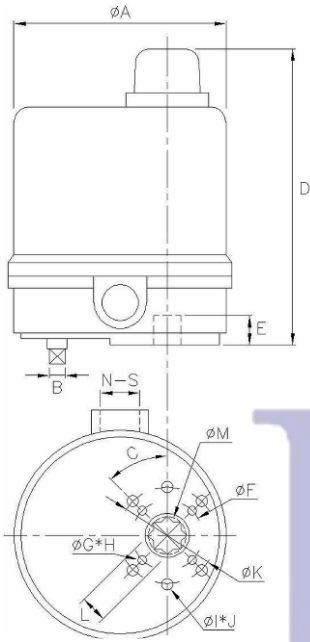

Option: (1) L = 11, M = 15
(2) L = 9, M = 12
With modulating card, D = 185

**Table (4b) Actuator Dimensions
(OM-2 to OM-3, OM-4 to OM-6)**

Model No.	A	B	C	D	E	F	G Max	H	I	M	N	S	Flange Type
OM-2 to OM-3	200	300	200	255	30	125	22	70	m8	4	2	½ PT	F07
OM-4 to OM-6	300	380	234	315	40	195	35	102	m10	4	2	½ PT	F10

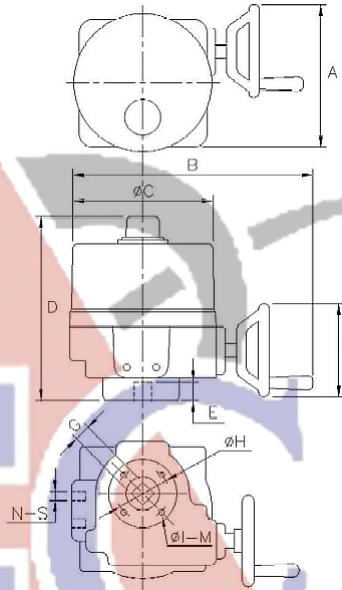

**Table (4c) Actuator Dimensions
(OM-7 to OM-8)**

Model No.	A	B	C	D	E	F	G	H	I	J	K	L	M max	N	S	Flange Type
OM-7 to OM-8	450	340	234	420	60	295	140	45°	m16	4	180	10	35	2	½ PT	F14

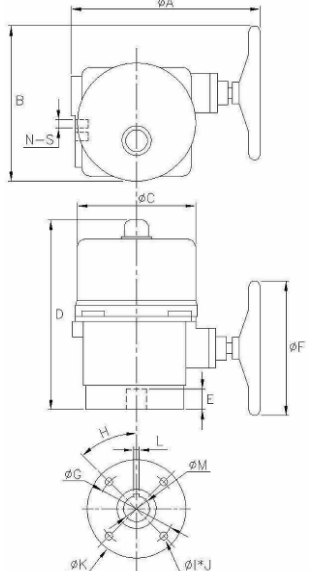

Note:
without torque switch A = 385

**Table (4d) Actuator Dimensions
(OM-9 to OM-12)**

Model No.	A	B	C	D	E	F	G	H	I	J	K	L	M	P	N	S	Flange Type
OM-9 to OM-12	470	350	260	590	100	395	45°	12	m20	4	75	165	221	360	2	½ PT	F16/F14

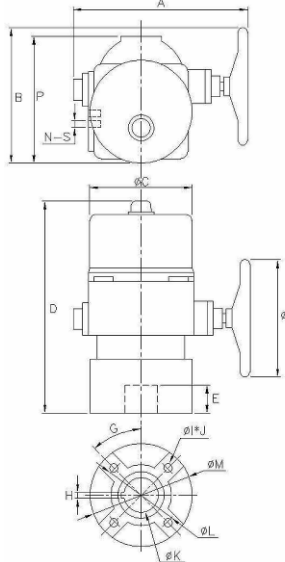

INSTALLATION

WARNING!

Remove power before the cover is dismantled!
The actuator must be handled with the utmost care when the cover is removed and the power connected!

ELECTRIC WIRING

Note:

Electric wiring must be carried out by qualified personnel only!

Wiring diagram is also shown on the label of top cover.

MOUNTING ON VALVE

Operate the valve manually to fully open or fully closed position before the actuator is mounted.

Operate the actuator and valve stem to fully open or fully closed position.

Check that the actuator and valve stem are in correct position. Please note, valve and actuator must be in the same mode (fully open/fully closed) prior to the assembly.

Mount the actuator on the valve and check that the actuator and valve stems are centered and aligned.

Operate the valve manually with the aid of the actuator hand-wheel and check that the valve moves with normal resistance.

Check that all screws are correctly tightened.

Loosen the screws on the cover and lift it off.

Check the voltage marked on the actuator label.

Connect according to the enclosed wiring diagram or if the actuator is of standard design, according to the wiring diagram below. The wiring diagram is drawn in unaffected position (the valve in the intermediate position).

Test run the actuator from intermediate position checking that the actuator turns in the correct direction.

Test run the actuator and check that the limit switches work correctly.

Check that the cable entries and possible blind plug are sealed.

Mount the cover.

WIRING DIAGRAM FOR MODULATING

[OM-1 & OM-A 110V / 220V AC 1-PH / Modulating Service]

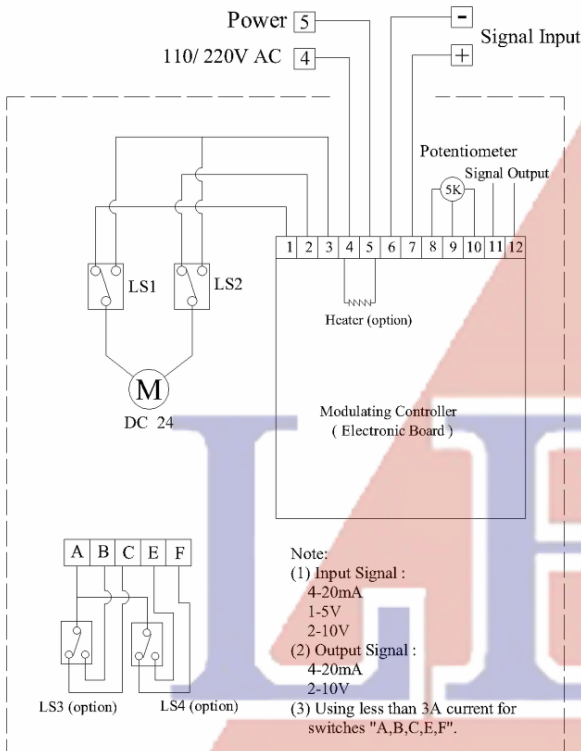

[OM-2 ~ OM-8 110V / 220V AC 1-PH / Modulating Service
30% Duty Cycle]

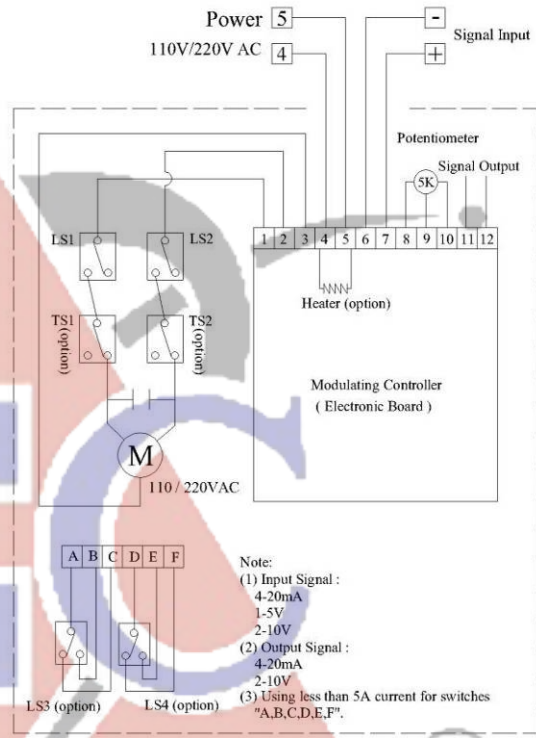

WIRING DIAGRAM FOR ON/OFF

[OM-1 & OM-A 110V / 220V AC 1-PH]

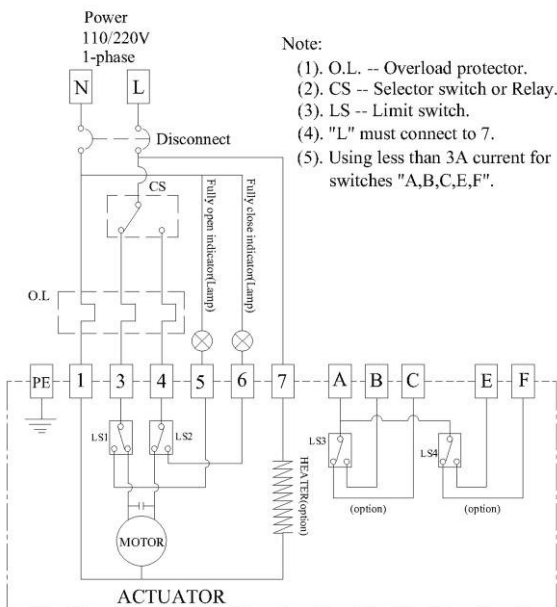

[BM-2,OM-2 ~ OM-12 110V / 220V AC 1-PH]

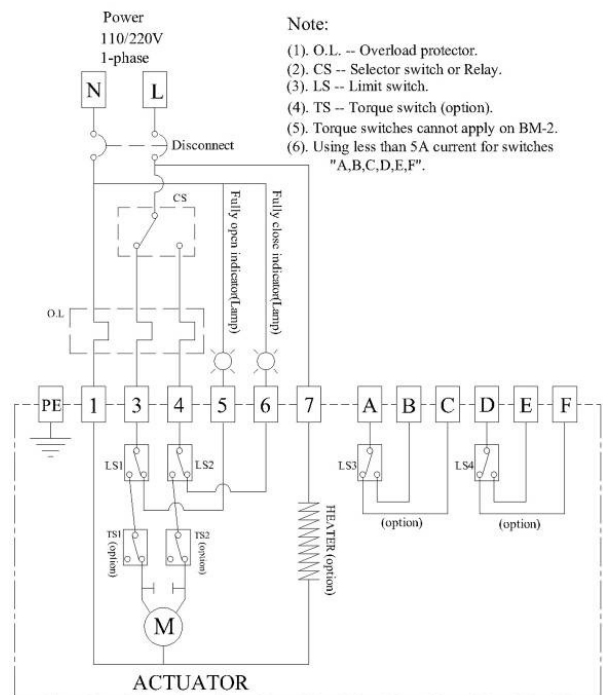

FUNCTION SETTING

Note:

Turn the power off before changing the following setting.

S1~S8: Function setting by DIP switches

S1, S2: DIP switches for input signal select

- "4~20mA" set 1-ON / 2-OFF.
- "1~5V" set 1-OFF / 2-OFF.
- "2~10V" set 1-OFF / 2-ON.

S3, S4, S5: DIP switches for feedback signal select

- "2~10V" set 3-ON / 4-OFF / 5-ON.
- "4~20mA" set 3-OFF / 4-ON / 5-OFF.

S6: DIP switch for direct/reverse action

Valve is fully-open when the input signal is 4mA, 2V or 1V and valve is fully-closed when the input signal is 20mA, 10V or 5V, set 6-ON.
 Valve is fully-closed when the input signal is 4mA, 2V or 1V and valve is fully-open when the input signal is 20mA, 10V or 5V, set 6-OFF.

S7, S8: DIP switches for valve position when input signal fails

- "valve fully-closed" set 7-OFF / 8-ON.
- "valve fully-open" set 7-ON / 8-OFF.
- "valve stops" set 7-ON / 8-ON.

SW1~0 (10 steps): Sensitivity adjustable switch

When switch to "1", the 0~90 degree can be divided up to around 80 times movement.
 When switch to "0", the 0~90 degree can be divided up to around 17 times movement.
 The sensitivity decreases 7 times movement by sectors from SW1 to SW2, SW2 to SW3, SW3 to SW4 and so on.

Modulating Control Board for OM2~12

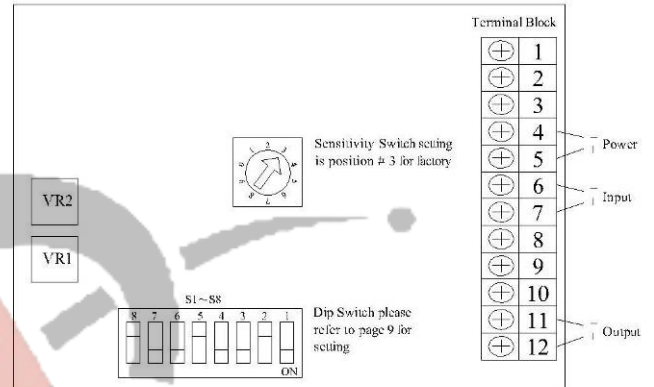

Modulating Control Board for OM1,OMA

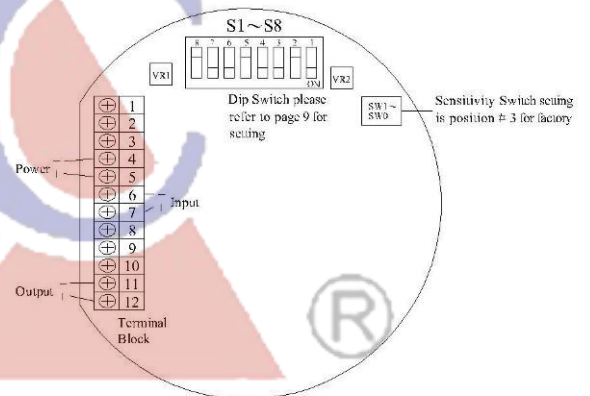

TROUBLE SHOOTING

Conditions	Possibilities	Solution
Motor does not operate	1. Is the supplied power and voltage correct?	1. Check by meter.
	2. Any blisters on the capacitor?	2. If so, replace.
	3. Are the gear train free?	3. Remove motor and check.
Motor stops running	1. Is the power supply short circuited?	1. Check wiring.
	2. Any foreign objects in flow stream?	2. Check for obstructions.
Unable to fully open/close	1. Loose/Misalign cam?	1. Adjust/Tighten using spanner.
	2. Bent valve stem?	2. Replace valve stem.
	3. Mechanical stop adjustment incorrect?	3. Check position of stops.
Valve stops operating when motor is running.	1. Gear worn out?	1. Replace gear.
	2. Sleeve adapter worn out or broken?	2. Replace sleeve adapter.
	3. Broken valve stem or actuator transmission shaft?	3. Replace valve stem or actuator transmission shaft.
Abnormal control for operating two or more actuators simultaneously.	Controlling circuit connects in tandem or parallel.	Refer to the wiring diagram.
Motor overheats	1. Is the voltage correct?	1. Check by meter.
	2. Is valve too tight to operate?	2. Replace valve.
	3. High duty working frequency?	3. Check duty cycle.
	4. Is motor stem bearing or blinding?	4. Replace the blinding parts.
Occasional on/off actuator failure.	Simultaneous input power on/off.	Check if the selectable switch is normal.
Vibration when valve is closed.	Motor brake spring fatigued or Teflon worn?	Replace spring or Teflon.



Honeywell

Automation and Control Solutions

Honeywell Taiwan Ltd.
 10F, 168 Lien Cheng Road
 Chung Ho City, Taipei County, Taiwan
 Phone: +886-2-2245 1000
 Fax: +886-2-2245 3241

Subject to change without notice. Printed in Taiwan

