

## R7428B1005

### CONSTANT RH & TEMP CONTROLLER WITH MODBUS

#### SPECIFICATION DATA



#### Features

- Cost effective solution for constant temperature and relative humidity control.
- Large LCD screen with back-light provides user-friendly MMI.
- Standard DIN rail or control panel mounting compatible.
- High resolution provides accurate control: 0.1°C for Temp & 0.1% for RH.
- Temp & RH value setting provides direct digital control.
- Preserve setting value while power failure.
- PID (Proportional Integral Deviation) control.
- Pre-configured application, no programming needed.
- Provide dual display for both Temp & RH.
- Selectable direct/reverse acting analog output.
- Sensor failure indication.
- For air-handling Unit control or universal control
- Dew point value will be calculated by temp. and RH%
- Modbus® communication device
  - Modbus® RTU protocol (9600bps, 1 stop bit, none parity)

#### Application

R7428B1005 Controller uses direct digital control technology to provide accurate and efficient operation for both Relative Humidity and Temperature controls of heating, ventilation, and air conditioning (HVAC) systems. Parameters are preset for plug and play operation and provide different control strategies for optimum system performance.

The controller performs proportional plus integral and deviation (PID) control and covers all space, supply air, water flow, heater and humidifier applications within the specified ranges of 0°C to 100°C for temperature and 10% to 99% for relative humidity. Standard NTC 20K ohm temperature sensors can be used.

The modern design with its easy to operate user interface and large LCD allows complete flexibility of control system design, accurate parameter setting, and display of actual temperature and relative humidity value, setpoints and outputs.

All the parameters in the controller can be read/write by the facility management system like Honeywell SymmetrE via Modbus RTU protocol (9600bps, 1 stop bit, none parity).

#### Specifications

Dimension:	See Fig. 1
Mounting:	Standard DIN rail or control panel mounting compatible
Wiring:	Maxima Wiring Run from Controller to All devices: 20 AWG
Control ranges:	SP1: 0~100°C SP2: -999°C~1000°C SP3: -99-1000
Working ranges:	0 ~ 50°C 5% ~ 95% (non-condensing)
Memory:	EEPROM
Power supply:	24 Vac, 50/60Hz
Input:	DI x 3: DPS, Remote, Alarm AI x 3: (selectable) 4~20mA or 0~10V (Humidity) 4~20mA or NTC20K (Outside Air) 4~20mA or NTC20K (Return Air)
Output:	DO x 3: Fan, Q1, Q2 AO x 3: Cooling Valve, heating valve, Humidifier

## Terminal Overview

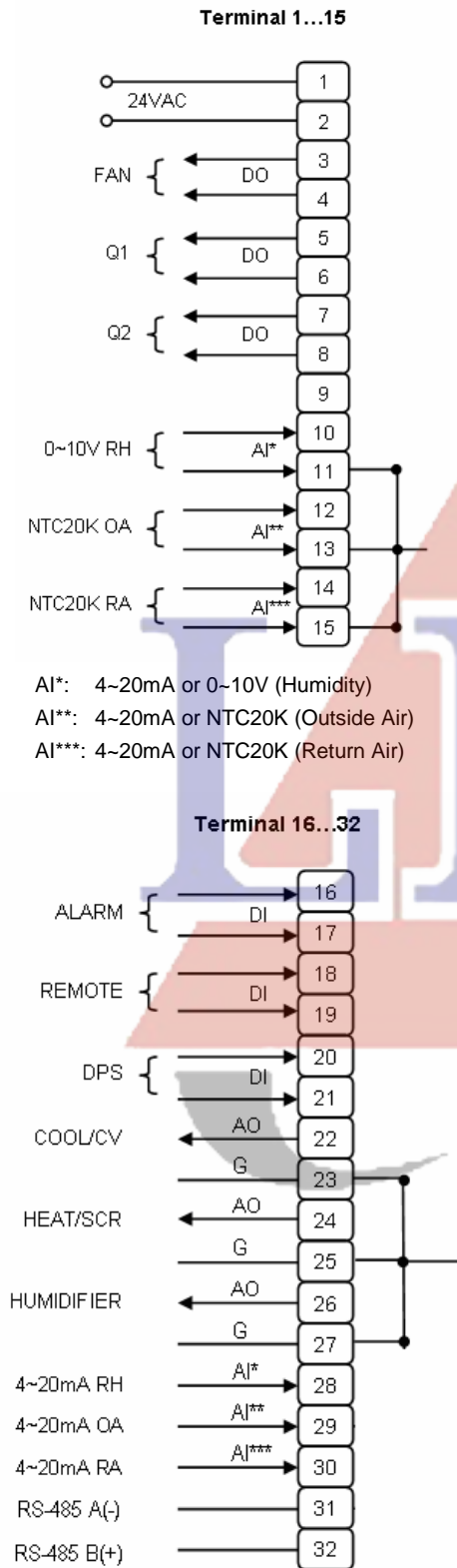

## Installation

### When Installing this Product...

1. Read these instructions carefully. Failure to follow them could damage the product or cause a hazardous condition.
2. Check the ratings given in the instructions and on the product to make sure the product is suitable for your application.
3. Installer must be a trained, experienced service technician.
4. After installation is complete, check out product operation as provided in these instructions.

## Dimensions

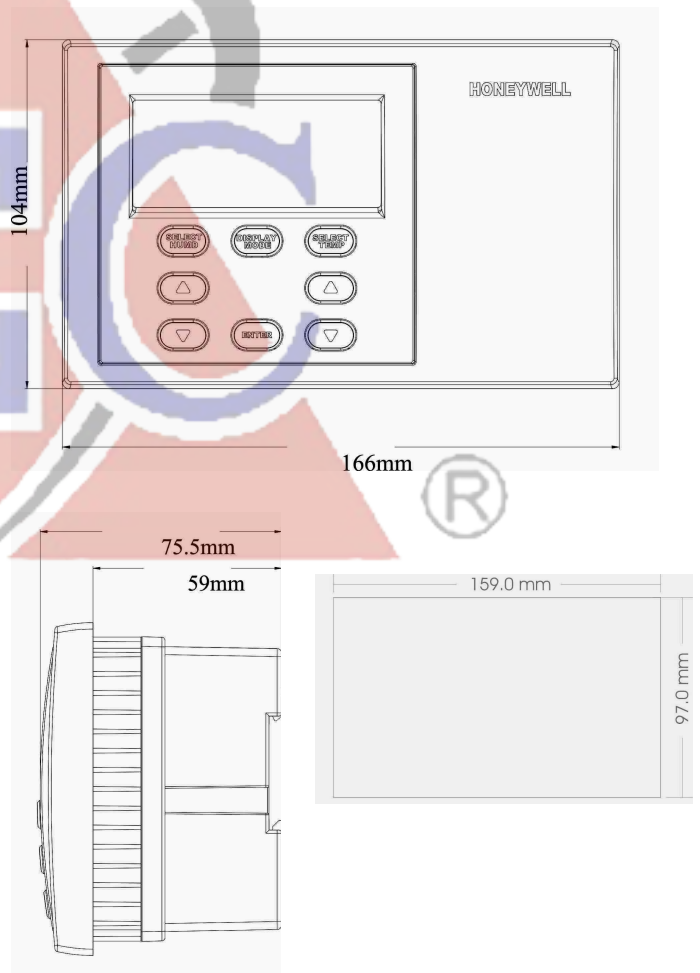

## Operating Overview

### Display and Operation Element

The user interface is shown in Fig. 2 & 3

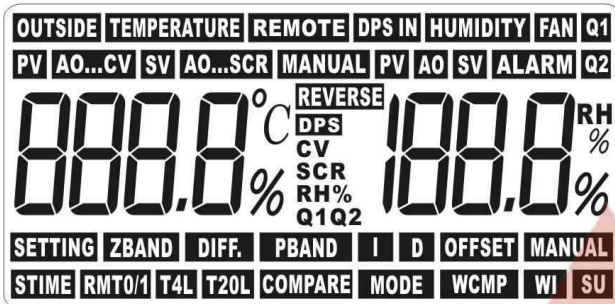

Fig. 2 LCD Screen

### LCD Screen Description

#### a. Temperature Setting Area

TEMPERATURE	Temperature Setting
AO...CV	Cooling Valve Output
AO...SCR	SCR Heating Valve Output
PV	Present Value
SV	Setting Value
MANUAL	Manual Mode
OUTSIDE	Outside Air Temperature

#### b. Humidity Setting Area

HUMIDITY	Humidity Setting
PV	Present Value
AO	Humidifier Output Value
SV	Setting Value

#### c. Status Indication Area

REMOTE	DI for Remote Control
DPS IN	Fan Status
FAN	Fan Start
ALARM	Alarm Status
Q1	Binary Sequence Indicator
Q2	Binary Sequence Indicator

MANUAL	Manual Mode
--------	-------------

#### d. Setting Status Area

ZBAND	Zero Energy Band
DIFF.	Q1 & Q2 Control Interval
PBAND	Proportional Parameter Setting
I	Integral Parameter Setting
D	Deviation Parameter Setting
OFFSET	Temp/RH Offset Setting
REVERSE	Output Mode Setting with CV, SCR, RH%, Q1Q2
DPS	DPS Interlock with CV, SCR, RH%, Q1Q2
MODE	Power Failure Mode Setting
COMPARE	Hi-Low Selector
MANUAL	Manual Mode Setting
WCMP	Compensation Changeover Point
WI	Winter Compensation
SU	Summer Compensation
CV	Cooling Valve Interlock (link with REVERSE or DPS)
SCR	SCR Heating Valve Interlock (link with REVERSE or DPS)
RH%	Humidifier Interlock (link with REVERSE or DPS)
Q1Q2	Q1Q2 Output Interlock (link with REVERSE or DPS)
STIME	Sampling Time Setting
RMT0/1	Remote Disable/Enable
T4L	4mA=(-20~+20°C) The minimum temperature of sensor (All sensors used in this controller must be in same temperature range)
T20L	20mA=(+50~+120°C) The maximum temperature of sensor (All sensors used in this controller must be in same temperature range)

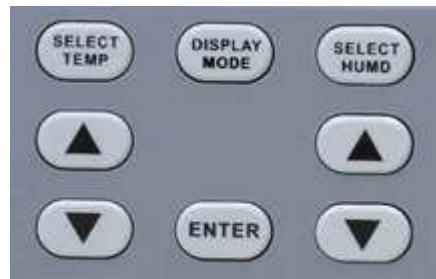

Fig. 3 Setting Buttons

### Button Description

1. Temperature Setting
  - a. SELECT TEMP: for Temperature setting and other configure selections.
  - b. ▲ ▼: Up-down selection.
  - c. Temperature configure sequence:  
ZBAND → PBAND → I → D → OFFSET → MANUAL → REVERSE → STIME → RMT0/1 → T4L → T20L → COMPARE → MODE → WCMP → W1 → SU → DPS → Q1Q2 → SCR PBAND
2. Humidity Setting
  - a. SELECT HUMD: for Humidity setting and other configure selections.
  - b. ▲ ▼: Up-down selection.
  - c. Humidity configure sequence:  
ZBAND → PBAND → I → D → OFFSET → STIME → T4L → T20L → HUMIDITY MODE
3. ENTER: Setting configuration
4. DISPLAY MODE: to switch the display of each item.
  - a. Common Mode:
    - i. TEMP display area: show the temperature of return air, "TEMPERATURE" & "PV" on.
    - ii. HUMD display area: show the present value of humidity, "HUMIDITY" & "PV" on.
  - b. Setting Mode:
    - i. TEMP display area: show the setting value of temperature, "TEMPERATURE" & "SV" on.
    - ii. HUMD display area: show the setting value of humidity, "HUMIDITY" & "SV" on.
  - c. Outside Air Mode:
    - i. TEMP display area: show the temperature of outside air, "OUTSIDE", "TEMPERATURE" & "PV" on.
    - ii. HUMD display area: show the present value of humidity, "HUMIDITY" & "PV" on.
  - d. Output Mode 1:
    - i. TEMP display area: show the output value percentage of cooling valve, "AO...CV" on.
    - ii. HUMD display area: show the output value percentage of humidifier, "HUMIDITY" & "AO" on.
  - e. Output Mode 2:
    - i. TEMP display area: show the output value percentage of SCR heating valve, "AO...SCR" on.
    - ii. HUMD display area: show the output value percentage of humidifier, "HUMIDITY" & "AO" on.
  - f. The display will change while pushing the button.