

ML8824A Series

Electric Linear Valve Actuator

Application

ML8824A Series electric linear valve actuators offer modulating controls for linear valves with position feedback signal, 0(2)-10Vdc or 0(4)-20mA. The products can be widely used with linear valves in heating, ventilation, and air conditioning application.

Features

- Quick and easy installation
- Lower power consumption
- Maintenance-free
- Self-adaption mode
- Adjustable travel speed
- Manual operation with override functions
- 0(2)~10 Vdc, 0(4)~20 mA input signal
- 0(2)~10 Vdc, 0(4)~20 mA position feedback signal
- Selectable travel direction

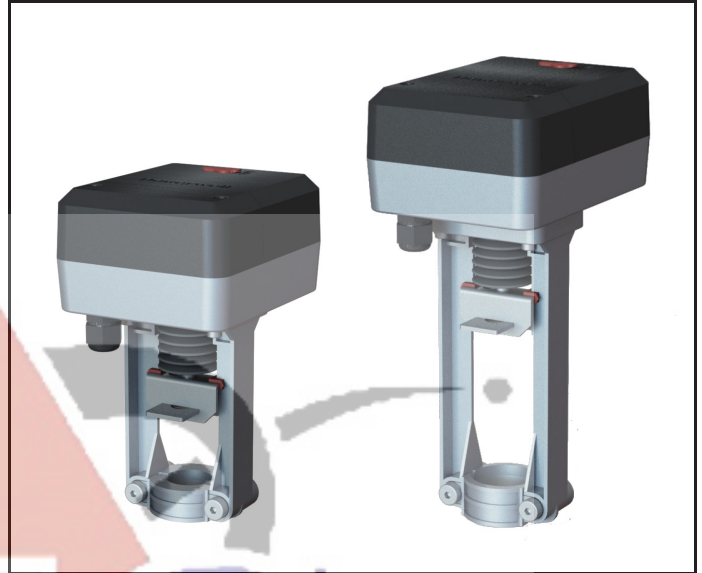

Technical Specifications

Temperature Limits

Ambient storage temperature -10~+55 °C (5~95% RH)
 Medium temperature -40~+65 °C (4~95% RH)
 Operating medium temperature up to 130 °C

Signals

Input signal 0~10 Vdc, 2~10 Vdc
 Voltage input impedance >100 KΩ,
 0~20mA, 4~20mA
 Current input impedance <0.125KΩ
 Feedback signal 0~10 Vdc, 2~10 Vdc,
 0~20mA, 4~20mA

Safety

Electrical protection class III (EN60730-1)
 Protection class IP54 (EN60730)

Materials

Upper Cover PC plastics
 Housing 600N - Plastics
 1800N - Cast aluminum
 Bracket Cast aluminum

Wiring

Terminal block	1.5mm ²
Cable connector	PG13.5
	PG9 connector for accessories Operation

Table 1. Model Selection

Model No.	ML8824A0620	ML8824A1820	ML8824A1840
Supply Voltage	24Vac ± 15% ,50/60Hz; 24Vdc +15% , -10%;		
Power Consumption	7VA	14.5VA	14.5VA
Signal input 1 0(2) Vdc or 0(4) mA	The valve connection is located at the bottom; 2-way valve "closed"; 3-way valve A-AB port "open" ①		
Signal input 2 10Vdc or 20mA	The valve connection is located on the top; 2-way valve "open"; 3-way valve A-AB port "closed" ①		
Feedback Signal	0(2)~10 Vdc, 0(4)~20 mA		
Rated Travel	20mm	20mm	40mm
Run time	60s or 80s	40s or 60s	80s or 120s
Close-off force	≥600N	≥1800N	
Weight	1.3kg	2.3kg	2.4kg

① Factory setting. Reverse actuation can be conducted through the 5th DIP switch on PCB.

Operation

Manual Operation

ML8824 series actuators can be manually operated through the accompanied hexagon wrench, and feature manual override function. In case of manual operation during power-on, the actuator will automatically cut off the power for the motor so as to ensure safety. **NOTE: After manual operations are completed with power off, the self-adaption process must be reactivated!** Rotate the hexagon wrench clockwise, and the actuator connection will move downwards; otherwise, the actuator connection will move upwards.

Floating Point Control Switching

ML8824 series actuators are provided with floating point control (see the wiring diagram). When the 8th DIP switch on PCB is ON, it indicates floating point control and the actuator will travel to the fully open or fully closed position without being controlled by the input signal.

Wiring Description

The actuator is pre-assembled with PG13.5 cable connector and provides PG13.5 and PG9 connectors for accessories. **NOTE:** To avoid any fault, please connect to 24 Vac power with ground connection (see the wiring diagram).

Self-Adaption Mode

Assemble the actuator and the valve, and supply the actuator with 24Vac/dc power.

Power-on self-adaption: The actuator will directly enter into self-adaption mode after being powered up. Meanwhile, the yellow indicator on PCB blinks (1Hz) and the actuator will be automatically full off (traveling to the bottom) and then full on (traveling to the top). When the indicator stops blinking, it means that the process is completed. Afterwards, the actuator will travel to the designated position of control signal.

Manual self-adaption: Press and hold button S1 on PCB for more than 5s (See Fig. 1) until the indicator starts blinking (1Hz) to enter into self-adaption mode. The actuator will be automatically full off (traveling to the bottom) and then full on (traveling to the top). When the indicator stops blinking, it means that the process is completed. Afterwards, the actuator will travel to the designated position of control signal.

NOTE: The self-adaptation process will take 3 minutes for 600N actuator and 4 mins for 1800N actuator (under factory default setting)

Input/Feedback Signal

The analog input/feedback signal is selectable through the DIP switch (see Table 2). The factory default input/feedback signal is 0...10 Vdc.

It is also possible for the actuator to input/output 2~10Vdc, 0~20mA, and 4~20mA signals, which requires changing of DIP switches on PCB (see Table 2).

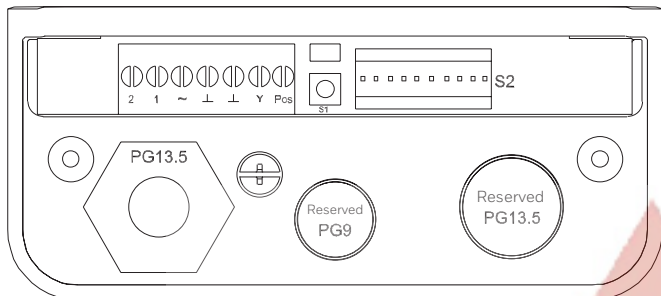

Fig. 1 PCB Layout

Signal Interruption Mode Description

The signal interruption mode can be set through the 6th DIP switch (see Table 2).

When the DIP switch is ON and the control signal is voltage or current type, the actuator will automatically provide a 0 (2) Vdc or 0 (4) mA signal (factory default) if the signal cable is cut.

When the DIP switch is OFF and the control signal is voltage type, the actuator will automatically provide a 10 Vdc signal if the signal cable is cut; in case of current type signal, the actuator will automatically provide a 0 (4) mA signal.

Setting of Traveling Direction

The traveling direction can be set through the 5th DIP switch (see Table 2).

When the DIP switch is ON, the input signal 0 (2) Vdc or 0 (4) mA is corresponding to the upper position of the actuator (factory default).

When the DIP switch is OFF, the input signal 0 (2) Vdc or 0 (4) mA is corresponding to the lower position of the actuator.

Table 2 DIP Switch Setting

DIP Switch	Function	Function Description of Setting Value	
S2-1	Setting of control/feedback signal	ON	20%: 4~20mA or 2~10VDC control/feedback signal
		OFF	0: 0~20mA or 0~10VDC control/feedback signal (factory default)
S2-2	Setting of control signal type	ON	II: The control signal is current type.
		OFF	UI: The control signal is voltage type. (factory default)
S2-3	Setting of control signal input impedance matching	ON	UI: The control signal is voltage type. (factory default)
		OFF	II: The control signal is current type.
S2-4	Setting of feedback signal type	ON	IO: The feedback signal is current type. (factory default)
		OFF	UO: The feedback signal is voltage type.
S2-5	Setting of operating mode	ON	DA: When control signal increases, actuator moves downward. When control signal decreases, actuator moves upward.
		OFF	RA: When the control signal increases, the actuator moves upward. When control signal decreases, the actuator moves downward. (factory default)
S2-6	Setting of signal interruption mode	ON	DW: When the control signal type is set as voltage or current, the actuator will automatically provide a minimum control signal cable is cut. (factory default)
		OFF	UP: 1) When the control signal type is set as voltage, the actuator will automatically provide a maximum control signal if the signal cable is cut. 2) When the control signal is set as current, actuator will automatically provide a minimal signal when the signal cable is cut.
S2-7	Setting of self-adaption mode	ON	DF: In power-on self-adaption mode. (factory default)
		OFF	RF: In manual self-adaption mode.
S2-8	Setting of control mode	ON	Floating control
		OFF	Modulating control (factory default)
S2-9	Reserved		
S2-10	Speed setting	ON	High speed: 600N - 3s/mm, 1800N - 2s/mm
		OFF	Low speed: 600N - 4s/mm, 1800N - 3s/mm (factory default)

Close-off Differential Pressure

Actuator Close-Off Force			600N	1800N	1800N
Actuator Rated Travel			20mm	20mm	40mm
Valve Type	Diameter (mm)	Diameter (inch)	Close-off Differential Pressure (kPa)		
V5GV2W050F-E	50	2	1000	1600	—
V5GV2W065F-E	65	2-1/2	1000	1600	—
V5GV2W080F-E	80	3	1000	1600	—
V5GV2W100F-E	100	4	—	—	1000
V5GV2W125F-E	125	5	—	—	1000
V5GV2W150F-E	150	6	—	—	1000
V5GV3W050F-E	50	2	200	700	—
V5GV3W065F-E	65	2-1/2	150	500	—
V5GV3W080F-E	80	3	100	350	—
V5GV3W100F-E	100	4	—	—	200
V5GV3W125F-E	125	5	—	—	130
V5GV3W150F-E	150	6	—	—	90

Wiring Diagram

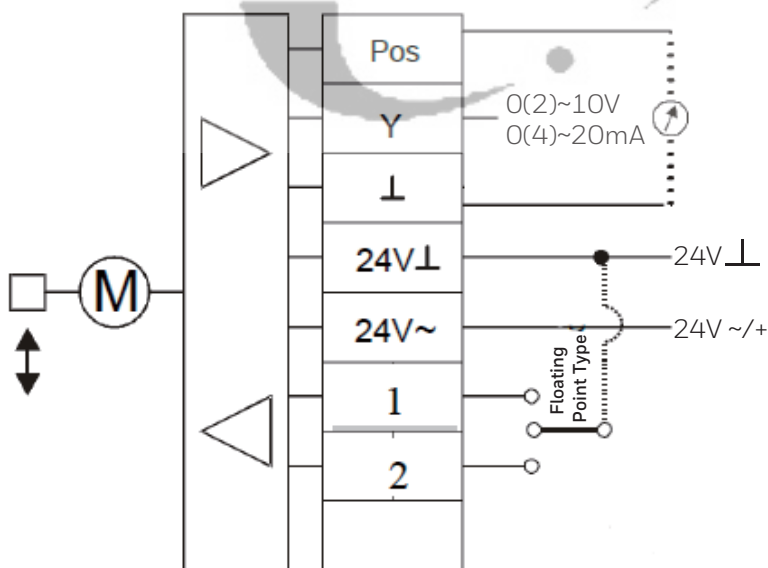

Description

1. Pos: Feedback signal
2. Y: Input signal
3. Floating control: See Table 2

Table 2 Floating Control
(when dip switch S2-8 is set to ON)

Terminal #	Actuator Motion
#1	Downwards
#2	Upwards

NOTE: Input signal is invalid for floating control.

Dimensions (mm)

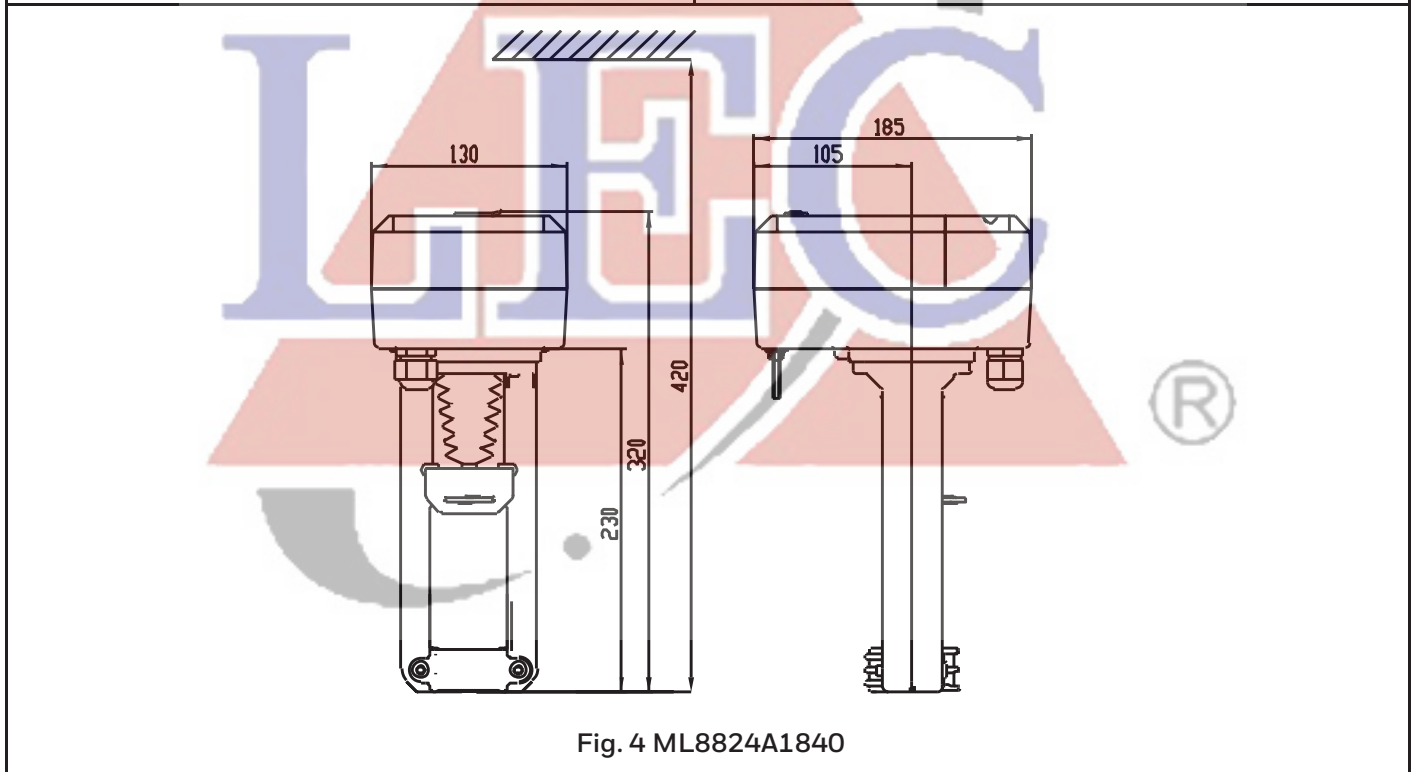
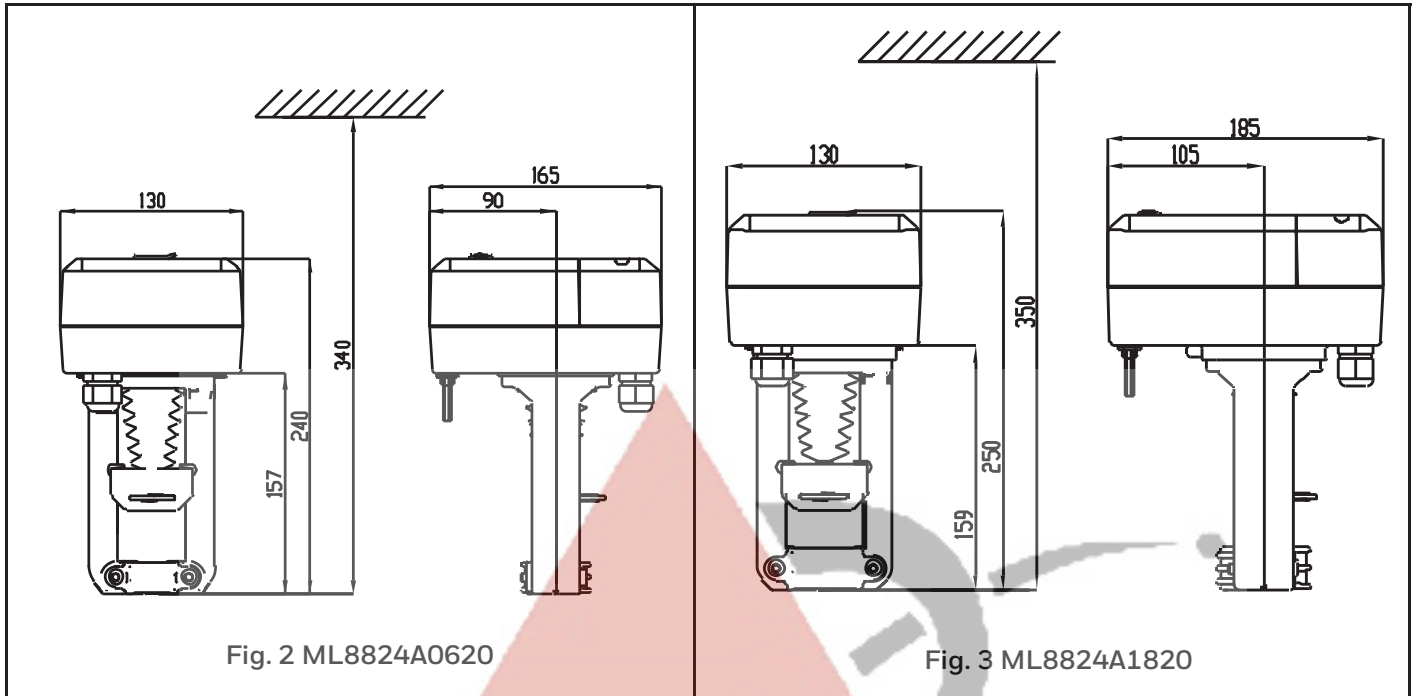

Honeywell Environmental and Combustion Controls (Tianjin) Co., Ltd.
No. 158, Nanhai Road, Tianjin Economic-Technological Development Area
Postal Code: 300457
Tel: +86-22-66287000
Fax: +86-22-25325214

Honeywell